

壓板·有溝槽，帶有可調整的反向件，以及T型螺栓 EH 23185.



產品描述

止推墊和反向元件與所述夾鉗是連接的，以固定防止損失。因此，夾鉗即可使用。而夾鉗配有兩個可被翻轉的扁平端視情況應用。

材質

- 螺絲
 - 熱處理鋼
- 螺帽
 - 熱處理鋼
- 碟盤
 - 熱處理鋼
- 鉗
 - 鋼，回火，鍍鋅，黑色

更多資訊

參考

更大的夾緊高度可透過支撐延展達到(EH 23185.)

更多產品

- 支撐延展，直形夾具、有溝槽、可調整的反向件

圖面

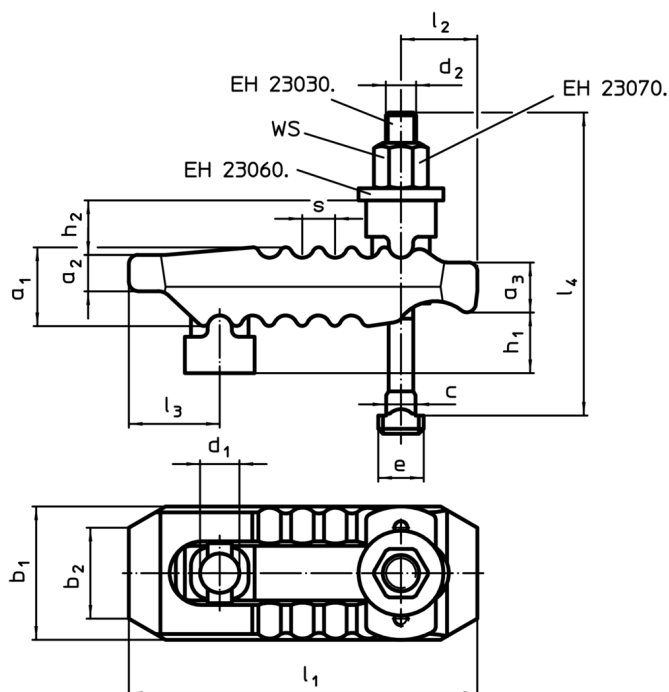

訂單資訊

標稱 昏暗。 d ₁ [mm]	T槽 尺寸 [mm]	尺寸															WS [mm]	夾持 力量 ¹⁾ max. [kN]	🏠 [g]	RoHS	REACH	品號
		d ₂	l ₄	h ₁	h ₂	a ₁	a ₂	a ₃	b ₁	b ₂	l ₁	l ₂	l ₃	e	c	s						
13	10	M10	100	0 – 40	18	27	12	17	44	30	115	25	30	15	9,6	11	16	25	660	RoHS 認證	contains no SVHC materials	23185.0110
13	12	M12	125	0 – 55	18	27	12	17	44	30	115	25	30	18	11,6	11	18	30	821	RoHS 認證	contains no SVHC materials	23185.0112
13	14	M12	125	0 – 55	18	27	12	17	44	30	115	25	30	18	11,6	11	18	30	841	RoHS 認證	contains no SVHC materials	23185.0113
17	12	M12	160	0 – 70	20	36	17	21	55	41	150	35	36	18	11,6	12	18	35	1683	RoHS 認證	contains no SVHC materials	23185.0114
17	14	M12	160	0 – 70	20	36	17	21	55	41	150	35	36	22	13,6	12	18	35	1701	RoHS 認證	contains no SVHC materials	23185.0115
17	16	M16	160	0 – 70	20	36	17	21	55	41	150	35	36	25	15,6	12	24	40	1850	RoHS 認證	contains no SVHC materials	23185.0116

¹⁾ 在最佳鉗緊位置鉗緊(插座頭到鉗緊位置的最短距離)。鉗緊力視夾鉗，插座頭的強度等級和螺紋條件判定

標稱 昏暗。 d ₁ [mm]	T槽 尺寸 [mm]	d ₂	l ₄	h ₁	h ₂	a ₁	a ₂	尺寸										WS [mm]	夾持 力量 ¹⁾ max. [kN]		RoHS	REACH	品號
								a ₃	b ₁	b ₂	l ₁	l ₂	l ₃	e	c	s	[mm]						
17	18	M16	160	0 – 70	20	36	17	21	55	41	150	35	36	25	17,6	12	24	40	1895	RoHS 認證	contains no SVHC materials	23185.0117	
21	16	M16	200	0 – 80	30	42	20	27	62	30	187	44	44	25	15,6	14	24	55	268	RoHS 認證	contains no SVHC materials	23185.0118	
21	18	M16	200	0 – 80	30	42	20	27	62	30	187	44	44	25	17,6	14	24	55	2704	RoHS 認證	contains no SVHC materials	23185.0119	
21	20	M20	200	0 – 80	30	42	20	27	62	30	187	44	44	32	19,6	14	30	60	2780	RoHS 認證	contains no SVHC materials	23185.0120	
21	22	M20	200	0 – 80	30	42	20	27	62	30	187	44	44	32	21,6	14	30	60	3005	RoHS 認證	contains no SVHC materials	23185.0121	
25	20	M20	250	0 – 100	31	51	24	34	70	30	235	60	47	32	19,6	17	30	70	4420	RoHS 認證	contains no SVHC materials	23185.0122	
25	22	M20	250	0 – 100	31	51	24	34	70	30	235	60	47	32	21,6	17	30	70	4460	RoHS 認證	contains no SVHC materials	23185.0123	
25	24	M24	250	0 – 100	31	51	24	34	70	30	235	60	47	44	23,6	17	36	75	4900	RoHS 認證	contains no SVHC materials	23185.0124	
25	28	M24	250	0 – 100	31	51	24	34	70	30	235	60	47	44	27,7	17	36	75	5000	RoHS 認證	contains no SVHC materials	23185.0125	

¹⁾ 在最佳鉗緊位置鉗緊(插座頭到鉗緊位置的最短距離)。鉗緊力視夾鉗，插座頭的強度等級和螺紋條件判定

應用範例

